

# **DoubleTrac<sup>®</sup>**

*Easy Installation. Zero Permeation.*

## ***Flexible Double Containment Piping Manual-January 2011***

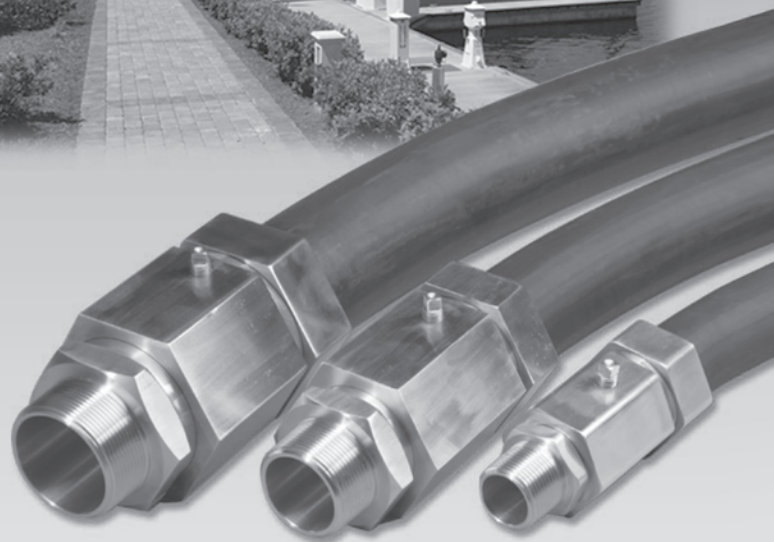

**OmegaFlex<sup>®</sup>**

[www.DoubleTrac.net](http://www.DoubleTrac.net)



## ***The Environmental Choice***

*Next Generation of UL971A*

*Flexible Double Containment Piping*

**TABLE OF CONTENTS**

INTRODUCTION ..... Page 2

LISTINGS AND APPROVALS..... Page 3

PRESSURE RATINGS ..... Page 3

OPERATING TEMPERATURE ..... Page 3

BEND RADIUS ..... Page 3

INSPECTION, HANDLING AND STORAGE ..... Page 3

ASSEMBLY OF DoubleTrac® BRASS FITTING..... Page 4

ASSEMBLY OF DoubleTrac® FLANGE FITTING..... Page 8

TIGHTNESS TESTING – PRIMARY..... Page 12

INSTALLATION OF CHECK VALVES..... Page 12

PIPE BURIAL, TRENCHING AND BACKFILL REQUIREMENTS..... Page 12

PENETRATION BOOT ..... Page 13

ROUTINE MAINTENANCE AND VISUAL INSPECTIONS ..... Page 13

CONTACT INFORMATION ..... Page 13

APPENDIX A FOR ABOVE GROUND AND MARINA APPLICATIONS..... Page 14

SECTION 1.0 – INTRODUCTION



DoubleTrac Underground, Above Ground and Marina Piping System

**▲ CAUTION**

This manual provides the installer with general instructions for the design and installation of underground, above ground and marina fuel piping systems using DoubleTrac® flexible petroleum piping system with built-in secondary containment.

This information deals primarily with underground, above ground and marina fuel piping. Other components of the piping system have their own individual installation instructions provided by the equipment manufacturer. The installation instructions provided by all component manufacturers must be followed for the underground, above ground and marina petroleum piping system to operate safely as designed.

The OmegaFlex DoubleTrac® flexible piping system must only be installed or serviced by a qualified installer who has been trained through the Underground, Above Ground and Marina Petroleum Piping Systems Installation Training Program. The use of non-trained personnel or any deviations from these written procedures could result in damage or leakage of the system and void the product warranty. Contact OmegaFlex Customer Service for more information at 800-355-1039.

These instructions must be used in conjunction with federal and state regulations for underground, above ground and marina bulk petroleum storage and piping.

All underground, above ground and marina fuel piping systems must be installed in accordance with recognized engineering practices. The industry standards for the installation of underground, above ground and marina tanks including piping systems are PEI RP 900-07, Recommended Practices for Installation of Underground, Above Ground and Marina Liquid Storage Systems, and Recommended Practices for Installation of Underground, Above Ground and Marina Petroleum Storage Systems.

At the completion of work this installation manual must be given to the site operator or owner.

**▲ CAUTION**

If the DoubleTrac® system is improperly installed, the contents of the piping may leak and possibly cause personal injury or damage to the environment. The instructions in this manual and applicable local codes must be strictly followed.



**Important Information Follow All Instructions**

**SECTION 2.0 - LISTINGS and APPROVALS**

OmegaFlex DoubleTrac® flexible piping system has both a primary and secondary containment jacket listed with UL 971A under file number MH 45578, titled: INTEGRAL PRIMARY/SECONDARY FOR ALL FUELS.

DoubleTrac® flexible piping may be used in the following applications.

- Pressure System Supply Piping
- Suction System Supply Piping
- Tank Vent Piping
- Stage II Vapor Recovery Piping
- Remote Fill Lines

**SECTION 3.0 - PRESSURE RATINGS**

DoubleTrac® flexible piping and fittings have a minimum five to one safety factor from the maximum rated operating pressure for the primary and secondary pipes. The product media should not exceed the maximum operating pressures indicated for each pipe size shown in Table 1.

**SECTION 4.0—OPERATING TEMPERATURE**

All DoubleTrac® products are rated for -20°F to +120°F.

**SECTION 5.0—BEND RADIUS**

DoubleTrac® flexible piping should never be bent at a radius smaller than the designed bend radius shown in Table 2.

**Table 2**

Pipe Size	Minimum Bend Radius
1"	12"
1-1/2"	24"
2"	32"

**SECTION 6.0 - INSPECTION, HANDLING and STORAGE**

Inspect all piping, fittings and components when they arrive at the job site. Any piping that has been cut, crushed, or otherwise subjected to physical damage during transportation or storage shall be discarded and never used. The piping and fittings shall be handled in such a manner that will not cause any unnecessary damage. Keep all components in the original packaging until ready for use. Inspect fittings prior to installation.

**▲ CAUTION**

**The end of the piping must be protected at all times. Extra caps are provided with each shipment.**

**Table 1**

Pipe Size	O.D. Nom	Weight	Primary Max Operating Pressure	Secondary Max Operating Pressure	Max Vacuum Rating
1"	1.55	0.75 lbs/ft	125 psig	50 psig	29" Hg
1-1/2"	2.30	1.50 lbs/ft	100 psig	50 psig	29" Hg
2"	2.93	2.00 lbs/ft	75 psig	50 psig	29" Hg

**SECTION 7.0—ASSEMBLY OF DoubleTrac® BRASS FITTING**

DoubleTrac® Containment fittings are to be assembled to piping per the procedure outlined below.

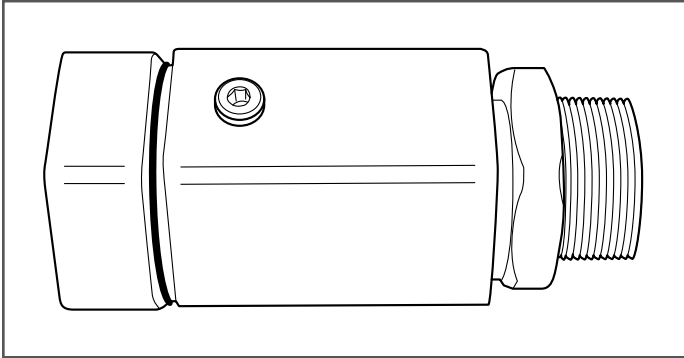

**Tools required for Assembly**

- Utility Knife with sharp blade
- Appropriate size adjustable wrenches
- Tubing Cutter

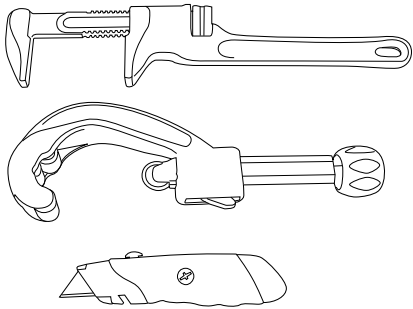

1. Unreel the flexible piping into the trench or on the ground and cut to the desired length – plus one foot. Cutting 1" size can be done with a tubing cutter. For sizes larger than 1", a reciprocating saw is recommended.

Be certain that proper pipe trenching, backfill materials and burial depth requirements are followed and in place prior to measuring and cutting DoubleTrac®. (See SECTION 12).

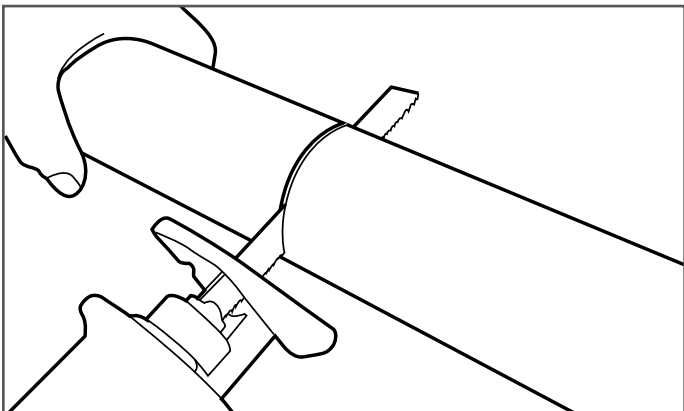

2. To assemble the fitting, strip a portion of the jacket from the stainless steel piping as follows. Locate the end of the piping and mark the sleeve at the length specified in Table 3 (rough cut).

**Table 3**

Pipe Size	Rough Cut
1"	3.25"
1-1/2"	3.25"
2"	3.25"

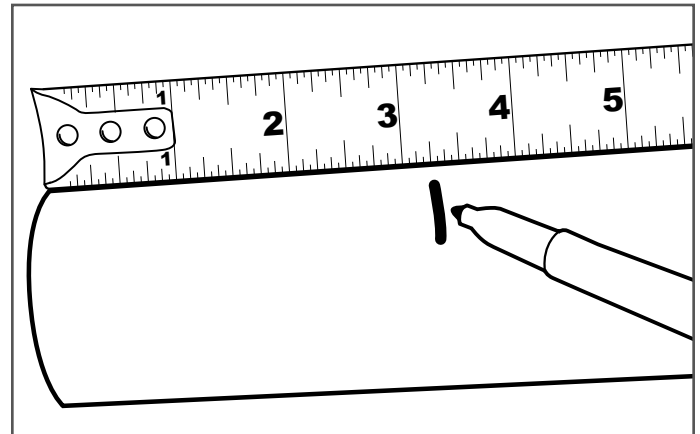

3. Using the tubing cutter, score the black sleeve approximately half of the way through all around the sleeve circumference. Use extreme caution not to cut or score the stainless corrugated pipe. Typically, no more than two turns on the cutter is sufficient.

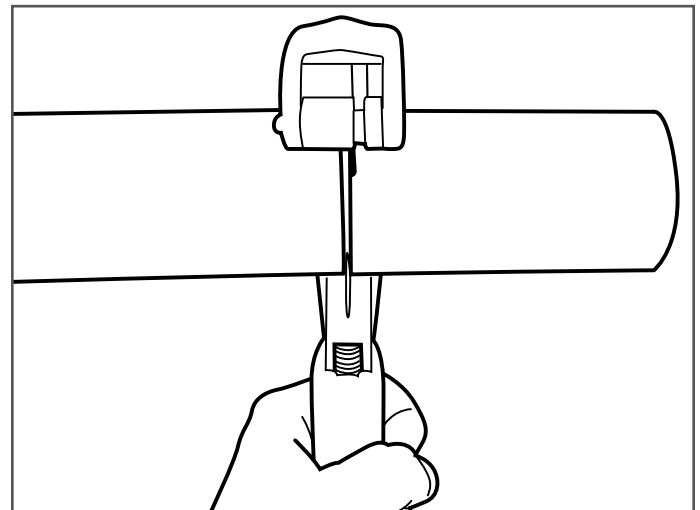

**Important Information Follow All Instructions**

4. Finish cutting through the outer jacket down to the stainless corrugated pipe using a sharp utility knife.

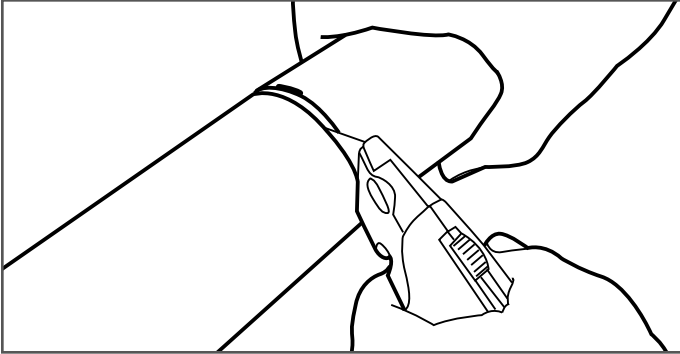

5. Using a twisting motion, remove the black sleeve from the pipe. It may be necessary to cut sleeve longitudinally and peel off for the larger sizes.

**▲ CAUTION**

**NOTE: Inspect the stainless steel pipe for scoring from the tubing cutter. If the stainless steel pipe is damaged, remove the damaged portion and repeat this procedure.**

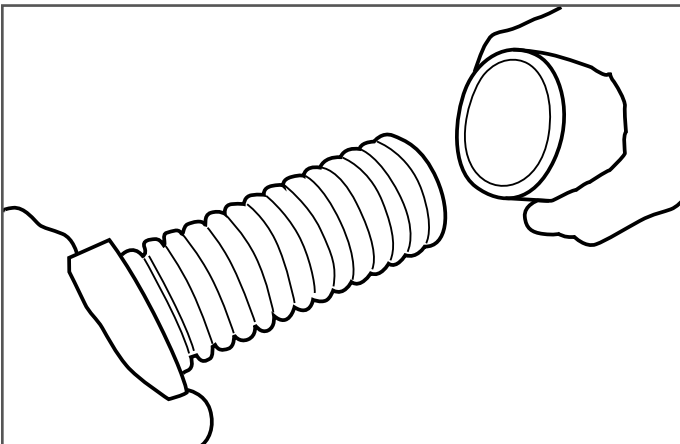
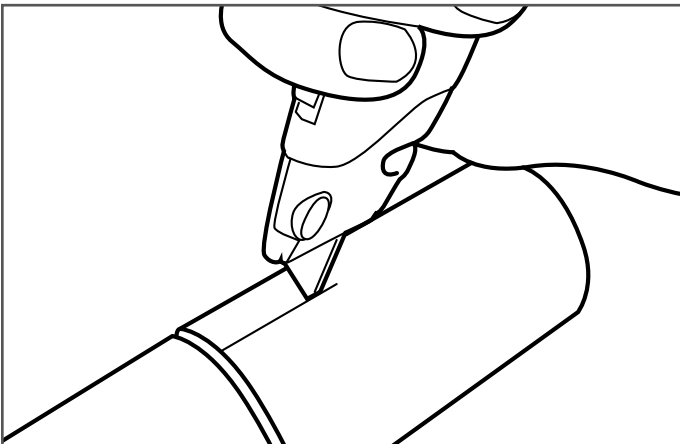

6. Remove the self flaring adaptor and split rings from the body.

Using a 5mm Hex wrench loosen the plug in body of fitting to allow the jacket to pass the bottom of plug.

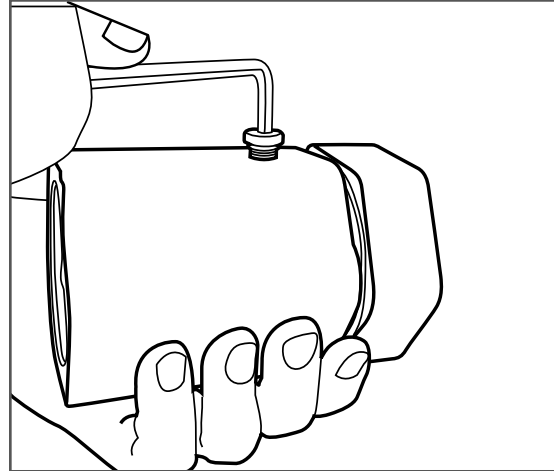

7. Slide the body onto the end of stainless steel corrugated pipe until it bottoms on the jacket.

Insert 1/2 of the split rings into the corrugation as close to the body as possible. Place a mark on the next root of a corrugation.

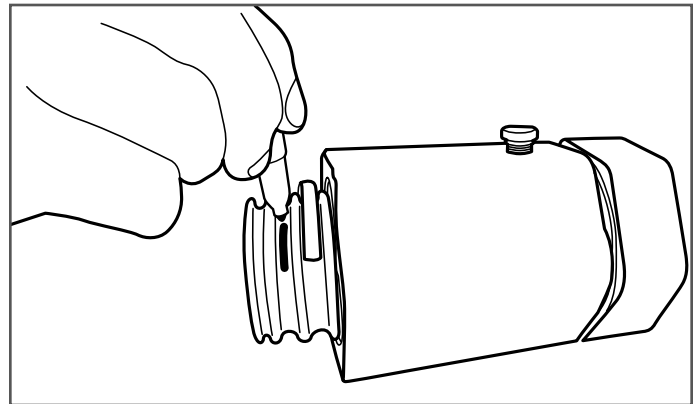

Remove the split ring and fitting body.

**Important Information Follow All Instructions**

8. Using a tube cutter trim the stainless steel corrugated pipe at the mark.

Cut slowly in the root of the corrugation in the same manner you would cut a piece of copper pipe. Inspect the end of the pipe for a clean cut without burrs in the corrugations.

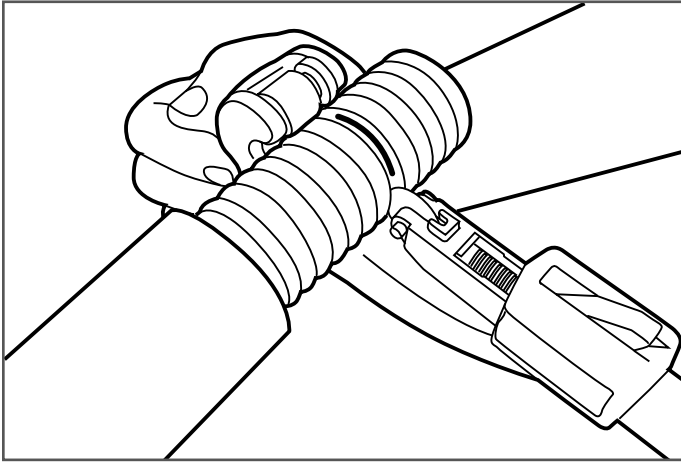

DoubleTrac® piping must be cut with the same type of tube cutter used for cutting copper tube. The cutting wheel must be sharp and large enough in diameter to avoid crushing the top of the inner stainless steel corrugation.

**▲ CAUTION**

**NOTE: When making the final cut, do not cut DoubleTrac® with a reciprocating saw or hack saw.**

9. Remove self flaring adaptor and split rings from the nut. Attach self flaring adaptor to the fuel dispensing equipment. Use pipe dope or sealant on the pipe threads only. Slip the nut, seal, washer, jacket lock, and body over the end of the pipe to expose the first corrugation. Insert split rings into the first corrugation.

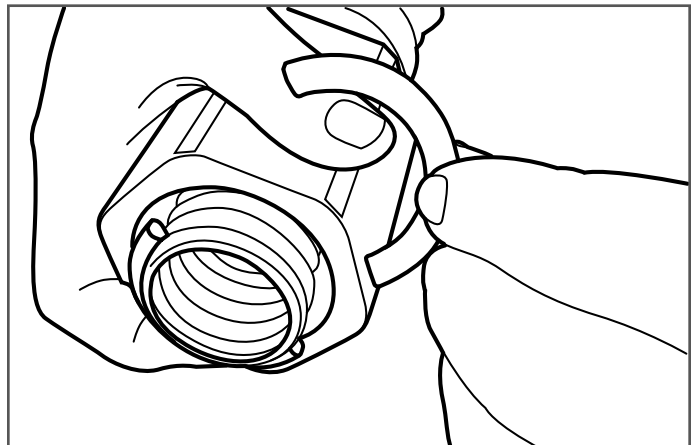
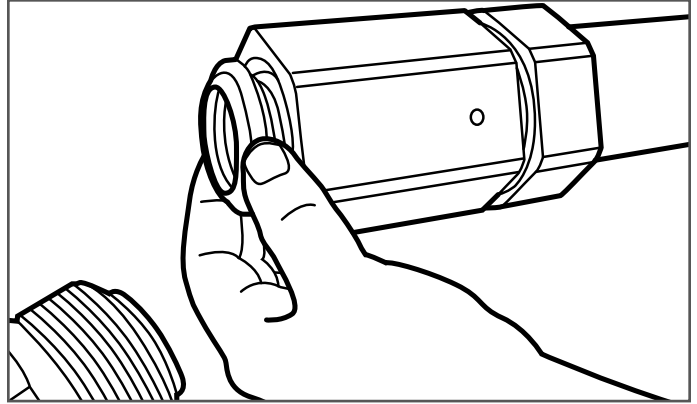

10. Holding the back nut, slide the body up to capture the split rings. Be sure rings slip all the way to the base of the threads in the body. Assembly is now ready to be attached to the self flaring adaptor on the equipment.

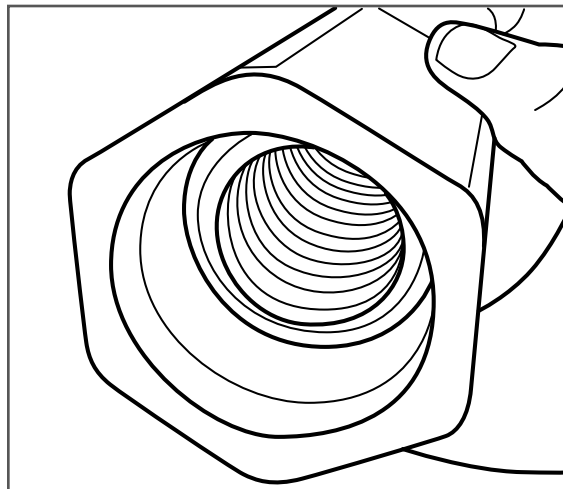

**Important Information Follow All Instructions**

**11.** Thread the body on to the self flaring adaptor previously installed on the equipment. Using appropriate wrenches hold self flaring adaptor and tighten the nut to the proper torque specified in Table 4.

**Table 4**

Pipe Size	Torque Coupling to Adaptor
1"	75 ft-lbs
1-1/2"	250 ft-lbs
2"	300 ft-lbs

**▲ CAUTION**

**NOTE: Do not over tighten or use any pipe dope or thread sealants on this connection. this is a metal to metal seat and will not seal properly if pipe dope or thread sealants are used. sealants are to be used on the npt connector to the equipment only.**

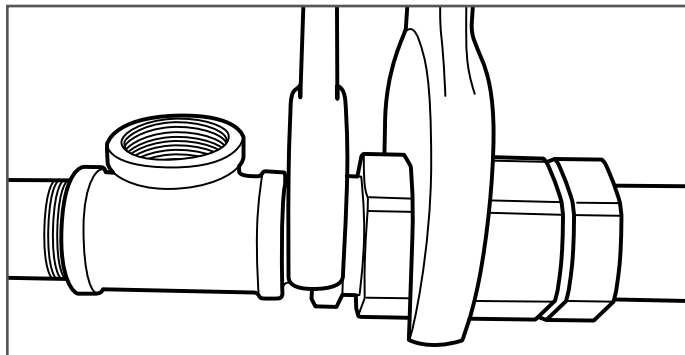

**11A.** As an alternative to the torque method: Tighten the nut and adaptor using the following method: Tighten the nut and adaptor as if you were making up a flared tubing joint.

Note relationship between hex flats at this point and continue to tighten for two additional hex flats (one third turn) to obtain required torque and final leak-tight seal.

For a quick visual inspection the space between the self flaring adaptor and body should be 1/16" of an inch after tightening.

**12.** Slide jacket nut, jacket lock, washers, and o-rings up to the coupling nut. Be sure jacket lock, washers and o-rings are seated in the base of the jacket nut squarely. Using appropriate wrenches hold coupling nut and tighten the jacket nut to the proper torque specified in Table 5.

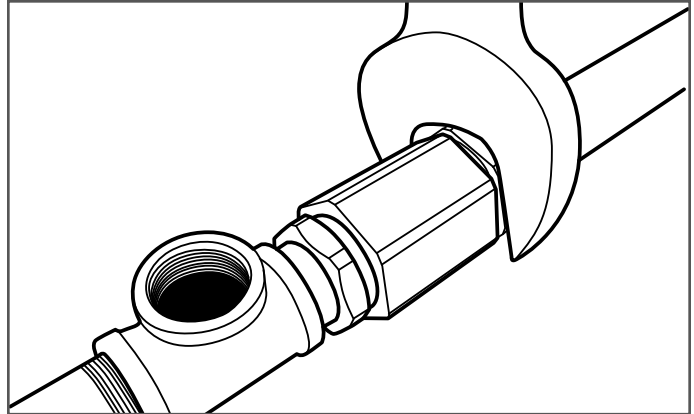

**Table 5**

Pipe Size	Torque Jacket Nut to Coupling
1"	75 ft-lbs
1-1/2"	275 ft-lbs
2"	350 ft-lbs

For a quick visual inspection the space between the jacket nut and body should be 1/16 of an inch after tightening.

**▲ CAUTION**

**NOTE: Do not over tighten or use any pipe dope or thread sealants on this connection. this is a metal to metal seat and will not seal properly if pipe dope or thread sealants are used. Sealants are to be used on the npt connector to the equipment only.**

**13.** Remove plug and install Schrader valve for secondary testing.

**SECTION 8.0 - ASSEMBLY OF DoubleTrac® FLANGE FITTING**

**1. Components**

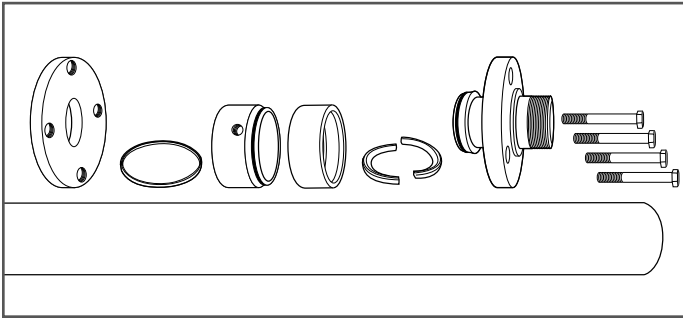

**2.** To determine the rough jacket strip length measure back 3" from the end.

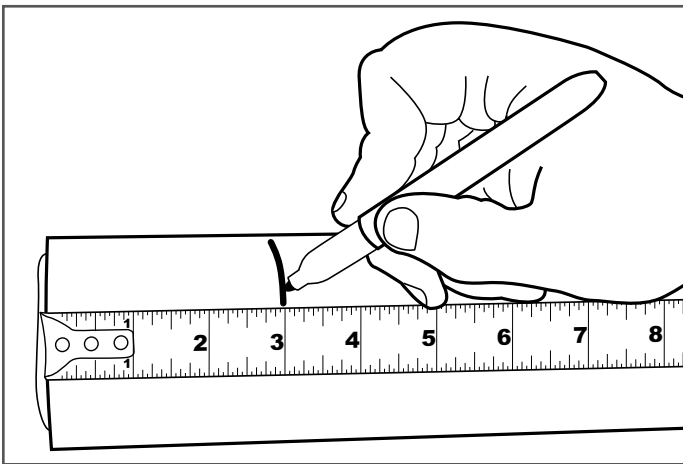

**3.** Using the tubing cutter, score the black sleeve approximately half of the way through all around the sleeve circumference. Use extreme caution not to cut or score the stainless corrugated pipe. Typically, no more than two turns on the cutter is sufficient.

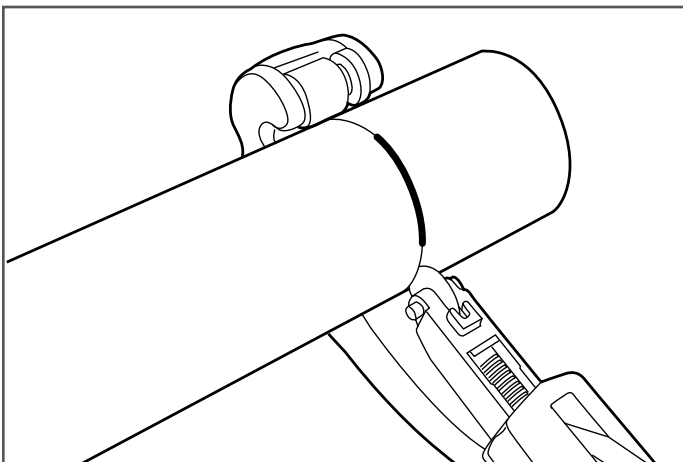

**4.** Finish cutting through the outer jacket down to the stainless corrugated pipe using a sharp utility knife.

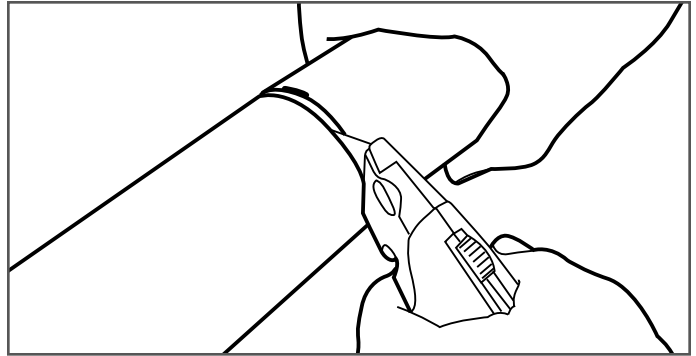

**5.** Carefully cut jacket with a utility knife for ease of removal. Do not score DoubleTrac® piping.

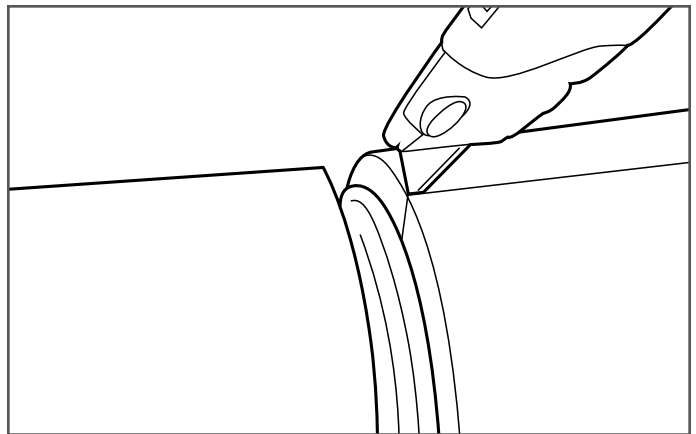

**6.** Remove portion of jacket

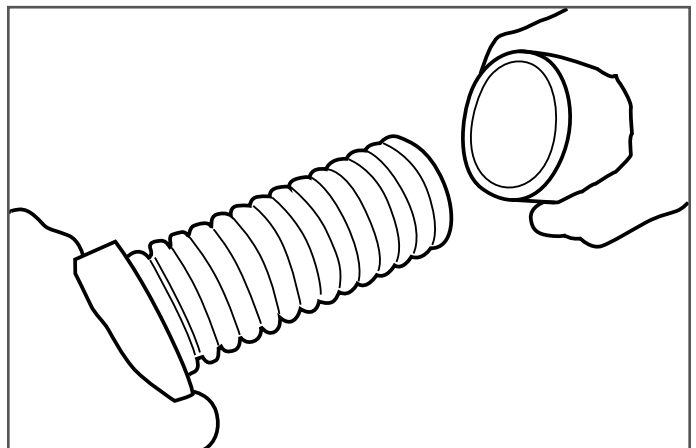

**▲ CAUTION**

**NOTE:** Inspect the stainless steel pipe for scoring from the tubing cutter. If the stainless steel pipe is damaged, remove the damaged portion and repeat this procedure.

**Important Information Follow All Instructions**

**▲ CAUTION**

Finishing the cut by bending or twisting may cause an improper seat.

**▲ CAUTION**

**NOTE:** When making the final cut, do not cut DoubleTrac® with a reciprocating saw or hack saw.

7. To determine the finished core length slide DoubleTrac® body over core and jacket until inner shelf of fitting bottoms out against jacket. Allow for the split ring (not shown) to be placed in the first corrugation valley against the fitting. Mark the second corrugation valley for the cut length.

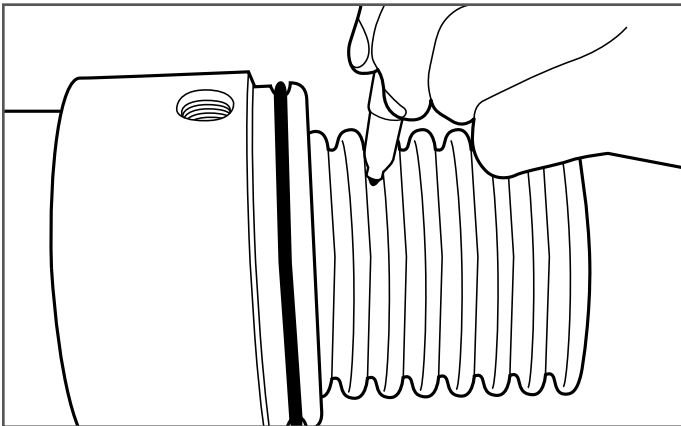

8. Cut in the valley of the corrugation marked in the previous step. The core must be carefully cut through completely using the pipe cutter.

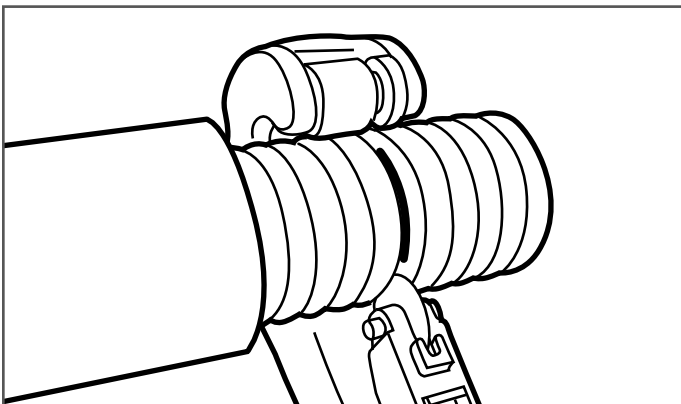

9. Slide tapped plate flange over DoubleTrac® piping. Make sure the chamfer on the inner I.D. of flange is facing the jacket.

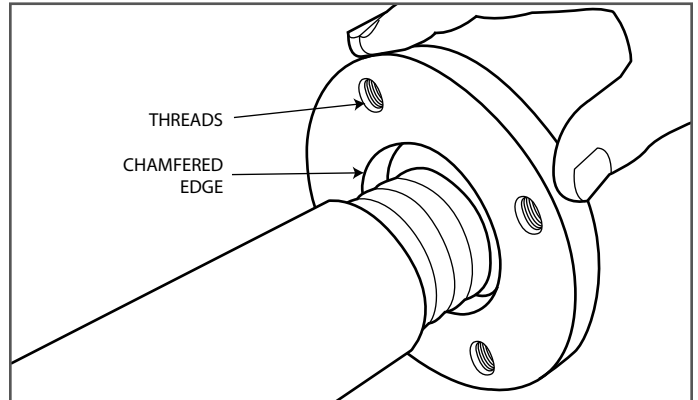

10. Slide brass jacket lock over DoubleTrac piping. The chamfered edge must be facing the bare core.

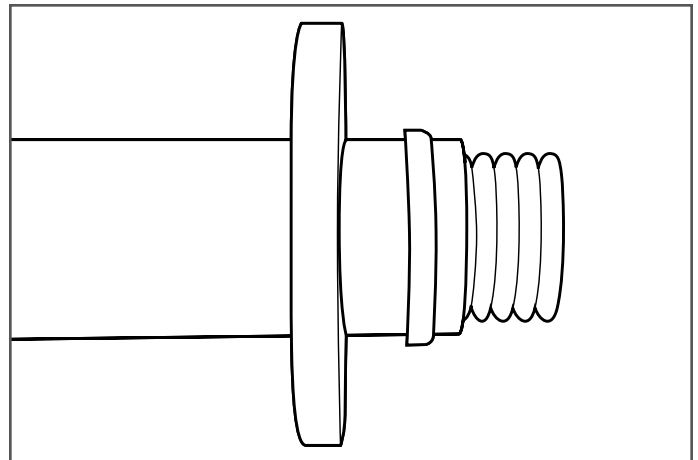

11. Slide DoubleTrac® body over core and jacket until the inner shelf bottoms out against jacket.

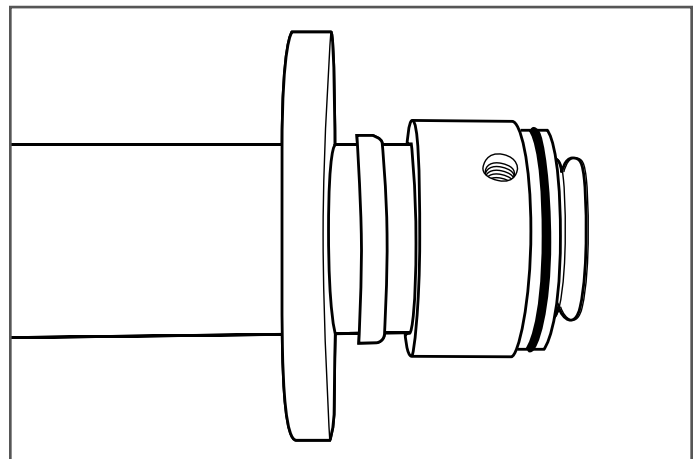

**Important Information Follow All Instructions**

**12.** Place the two split rings into the closest allowable corrugation valley against the fitting body.

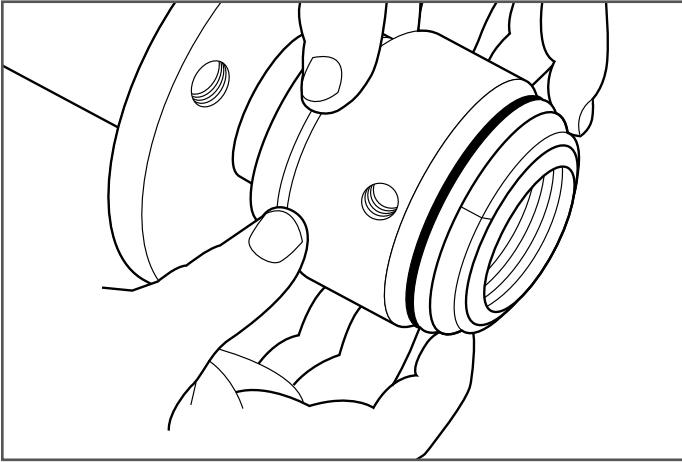

**15.** Slide untapped flange over NPT adapter. Make sure the neck of the flange is facing towards the threads.

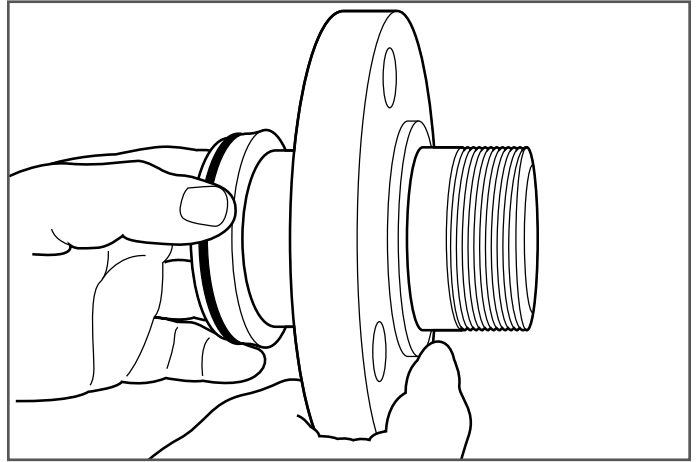

**13.** Slide DoubleTrac® retainer over o-ring against DoubleTrac® body.

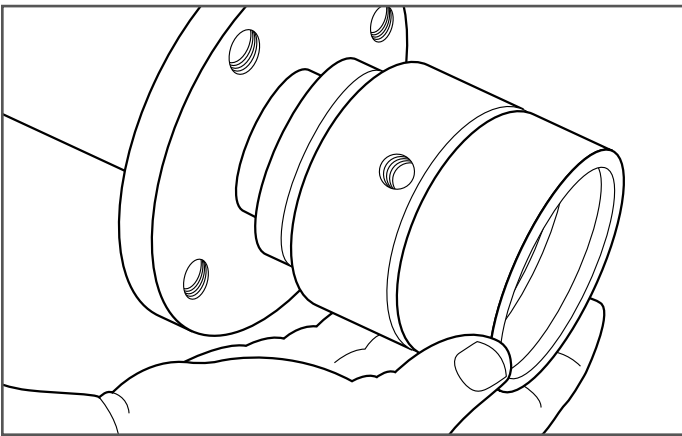

**16.** Compress snout into DoubleTrac® retainer.

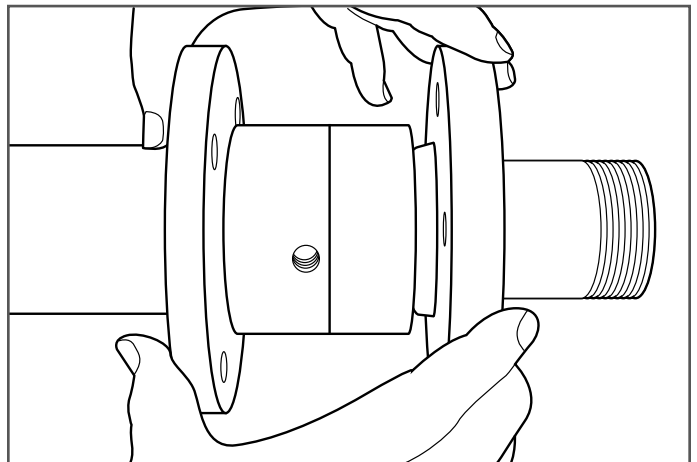

**14.** Compress DoubleTrac® retainer against DoubleTrac® body.

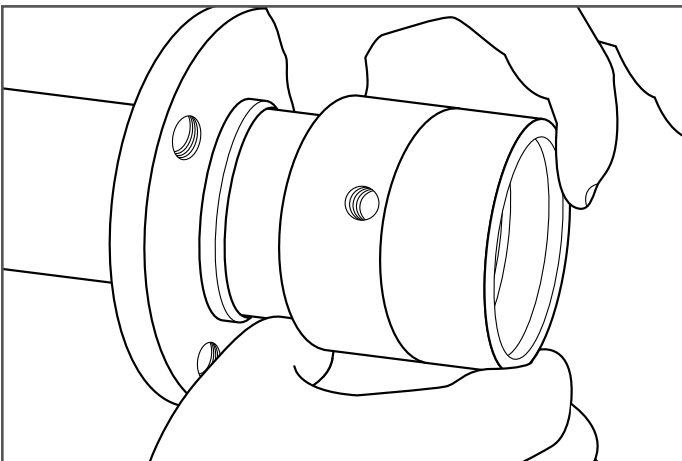

**17.** Start all bolts evenly.

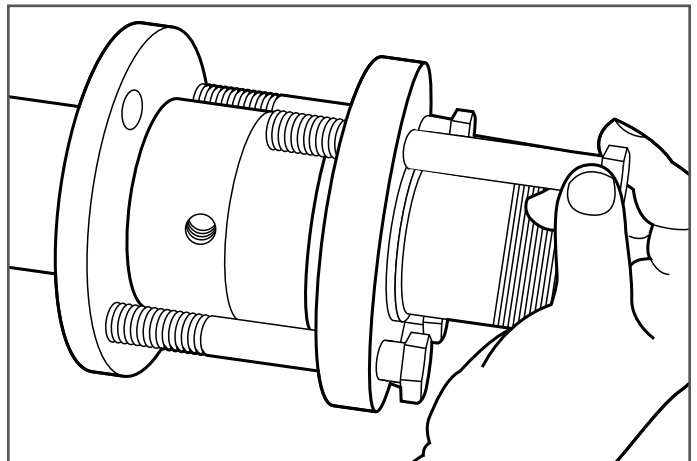

**18.** Tighten all bolts evenly, to 50 ft-lbs of torque.

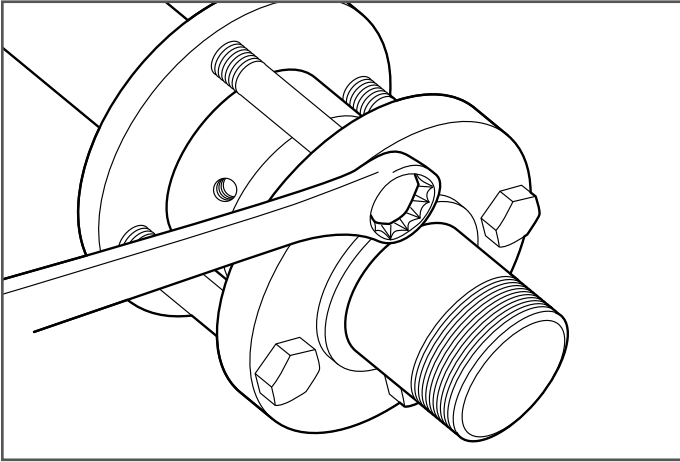

**20.** Finished assembly.

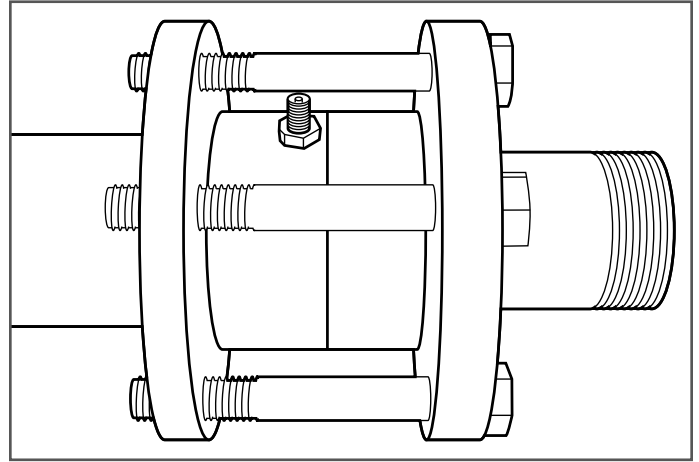

**19.** Insert and tighten Schrader valve.

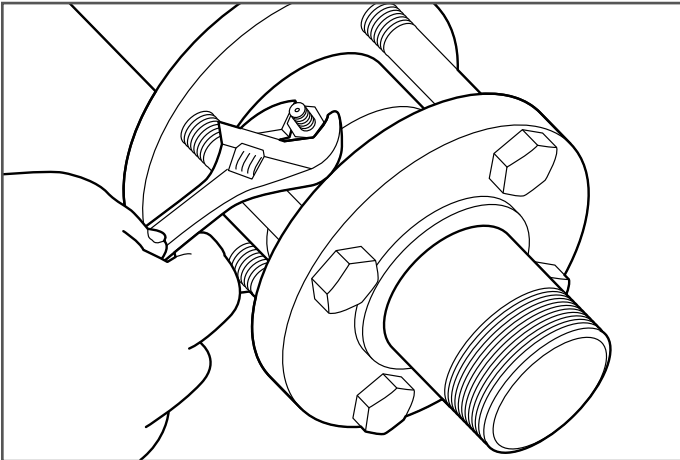

**Important Information Follow All Instructions**

**SECTION 9.0 - TIGHTNESS TESTING OF SECONDARY CONTAINMENT PIPING**

For tightness testing of DoubleTrac® flexible piping, the secondary piping is pressurized with air to a level 1.5 times the operating pressure of the secondary containment system but not less than 10 psig. At a minimum, the pressure test shall last for one hour, no loss of pressure allowed. All joints should be wetted with a non-corrosive leak test solution and inspected for bubbles. The use of “soap” solutions is not permitted with stainless steel piping due to the corrosion potential of chlorinated compounds.

The installer shall deliver a copy of the test results to the site owner or operator, who shall keep a copy of all final test results.

**NOTE: When testing the secondary, the primary is also being tested.**

**▲ CAUTION**

**NOTE: When performing a tightness test, the piping must be completely isolated from the rest of the system.**

**SECTION 10 - TIGHTNESS TESTING OF PRIMARY PIPING**

Before the piping system is backfilled, it must be isolated from the tanks and subjected to a pipe tightness test on the primary and secondary piping.

For tightness testing of DoubleTrac® flexible piping, the primary piping is pressurized with air to a level of 1.5 times the operating pressure of the system. Maintain this pressure for a minimum of one hour, making sure there is no drop in pressure.

**SECTION 11—INSTALLATION OF CHECK VALVES**

Once all testing has been completed, remove body of Schrader valve and thread on check valve to Schrader valve. The arrow on the check valve should point away from the fitting.

**▲ CAUTION**

**NOTE: If check valves are not installed, then the plug which originally came with the fitting must be installed. Prior to releasing for service, either a plug or check valve must be installed. Failure to do so voids all warranty.**

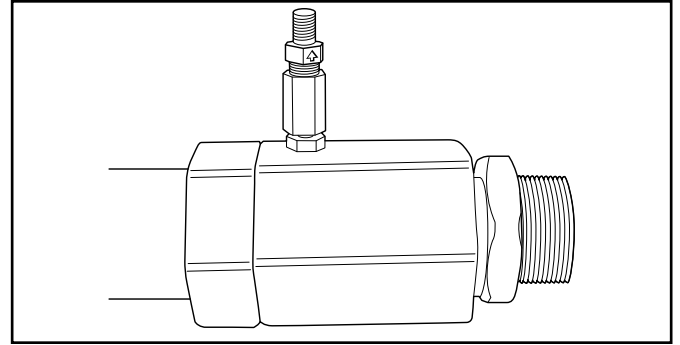
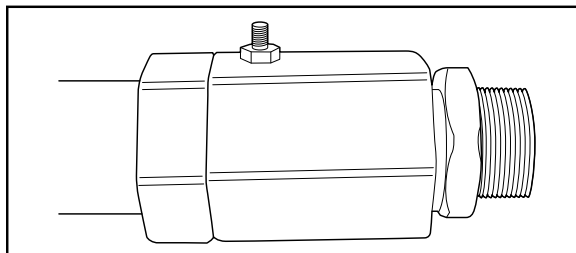

**NOTE: Regardless of fittings used, Brass fittings in section 7 or Stainless Steel Flange fittings in section 8, a check valve must be installed.**

**SECTION 12—PIPE BURIAL, TRENCHING AND BACKFILL REQUIREMENTS**

Provide a trench width equal to the pipe diameter plus six inches on each side. Separate multiple lines by at least 4 inches. The distance between any piping and the trench excavation walls must be at least 6 inches. For example, an installation of three 2” diameter pipes, the trench would be 26” wide and a minimum of 26” deep.

Whenever possible, product lines should be run in a single trench between the tank area and pump dispenser island area. Vent lines between the tank and the structure to which the aboveground vent lines are attached should also be installed in a single trench. Where more than one trench is required, piping should not cross over each other or cross over underground, above ground and marina tanks.

The trench bottom must be sloped uniformly from the dispensers back to the tanks or sumps at a minimum slope of 1/8 inch per foot and be free of any sharp or protruding hard objects. The trench bottom must be graded with a minimum of six inches of backfill such as washed sand, or pea gravel.

For backfilling, provide a minimum level of clean backfill between the top of the pipe and the surface as provided in Table 6.

**Table 6**

Surface Pavement	Min. Depth of Pavement	Min. Level of Clean Backfill
Unpaved	N/A	18"
Asphalt	2"	8"
Reinforced Concrete	4"	4"

**▲ CAUTION**

**Native back fill materials should never be used.**

**SECTION 13 – PENETRATION BOOT**

OmegaFlex recommends the boots shown in tables 7 and 8 to properly mate up with DoubleTrac piping. These boots have been evaluated to proper sizing, although other boots and manufacturers might also be compatible. All boots must meet local, state, and federal regulations for bulk petroleum storage and piping.

**Table 7 - DoubleTrac Pipe Size-Recommended Industry Boots for Single Wall Sumps**

DoubleTrac Pipe Size	O.D. Nom	Diversified Part No.	Blueline Part No.	APT Part No.	OPW Part No.
1" DoubleTrac	1.55	U8S-1.6	KFD1.6	FEB-100-SC	
1 1/2" DoubleTrac	2.30	U8S-2.4	KFD2.5	FEB-175-SC	EBF-0200F
2" DoubleTrac	2.93	U8S-3.0	KFD3.0	FEB-200-SC	

**Table 8 - DoubleTrac Pipe Size-Recommended Industry Boots for Double Wall Sumps**

DoubleTrac Pipe Size	O.D. Nom	Diversified Products Part No.	Blueline Part No.
1" DoubleTrac	1.55	U8M-1.6	K2DW1.6
1 1/2" DoubleTrac	2.30	U8M-2.4	K2DW2.5
2" DoubleTrac	2.93	U8M-3.0	K2DW3.0

**SECTION 14 – ROUTINE MAINTENANCE AND VISUAL INSPECTIONS - PROBLEMS**

It is recommended that a visual inspection of the inside of all containment sumps be completed at least once per month. Fuel leaks collected in containment sumps must be reported immediately and investigated by the site owner. If leakage or damage to the piping system is suspected, OmegaFlex must be notified immediately.

All sumps must be kept free of fuel, water and debris. When changing fuel filters at the dispenser, make sure any spilled product is cleaned out of the bottom of the dispenser sump to prevent possible fire hazard.

**SECTION 15 – OmegaFlex Inc. Contact Information**

OmegaFlex Inc. can be contacted if there are any questions concerning the installation, maintenance or repair of DoubleTrac® flexible piping system. Please contact OmegaFlex customer service and 1-800-355-1035 or on the web at [www.omegaflex.com](http://www.omegaflex.com) or [www.doubletrac.net](http://www.doubletrac.net).

**▲ CAUTION**

**Ignoring or disabling leak detection alarms can lead to further damage and possible failure of the system.**

**Failure to remove fuel and liquids from the containment sumps may compromise the performance and integrity of the sump and its associated fittings (entrance boots) and seals over prolonged periods of time.**

APPENDIX A

**DoubleTrac® Piping Guide for Above Ground Applications**

**Overview**

DoubleTrac® piping is a proven flexible piping system that has both a primary and a secondary containment jacket listed with UL971A under file number MH45578. DoubleTrac's® innovative double wall design includes a primary interior layer of zero-permeation, highly corrosion resistant corrugated stainless steel with an outer EFEP barrier layer bonded to a Nylon 12 protective layer. The unmatched strength of stainless steel combined with the superior chemical resistance of EFEP in the secondary barrier layer provide a highly durable design utilizing proven materials in the industry. The interstitial space provides continuous monitoring for leak detection—making DoubleTrac® the industry's most effective Zero Permeation piping solution. This piping is suitable for use in marinas, harbors, fuel terminals, fuel oil lines, and emergency generator feed and return lines.

**Operating Parameters**

SIZE	1"	1.5"	2"
MAX WORKING PRESSURE (psig)	125 Primary 50 Secondary	100 Primary 50 Secondary	75 Primary 50 Secondary
MINIMUM BEND RADIUS (inches)	12	24	32
WEIGHT (lbs / ft)	0.75	1.50	2.00
OPERATING TEMPERATURE (deg F)	-20 / 120		

**Application Basics**

All installations must be performed by a trained operator. Typically each installation is unique and requires some level of review; however there are some general guidelines that are applicable to all installations. Inspect all piping, fittings and components when they arrive at the job site. Any piping that has been cut, crushed, or otherwise subjected to physical damage during transportation or storage shall be discarded and never used. The piping and fittings shall be handled in such a manner that will not cause any unnecessary damage. Keep all components in the original packaging until ready for use. Inspect fittings prior to installation.

Maintaining a continuous slope from the dispenser to the tank is oftentimes not possible; specifically regarding marina refueling systems. Maintain a uniform slope for as much of the piping as feasible, whether the slope is toward the tank or toward the dispenser. To the extent practical, minimize the number of times the direction of the piping slope changes.

In particular, marinas have some specific requirements. Additionally, refer to the DoubleTrac® design and installation guide (DBT-001) for proper fitting assembly technique.

### Outdoor Installations

When installed outdoors, the DoubleTrac piping must be adequately protected from puncture, shear, crush or other physical damage threats, including possible damage from:

- vehicular or pedestrian traffic, corrosion,
- twisting, bending, kinking, chafing, or other excessive or prolonged movement of the piping,
- construction and excavation,

When installed along the side of a structure in an exposed condition, the DoubleTrac piping shall be installed in a location which will not subject the piping to mechanical damage. NOTE: For support and protection, OmegaFlex recommends that outside runs along the side of a building be clipped securely to the wall or other structural component every six feet. Typical supports are Unistrut conduit hangers, “U” bolts, PVC pipe couplers, or Hosebuns.

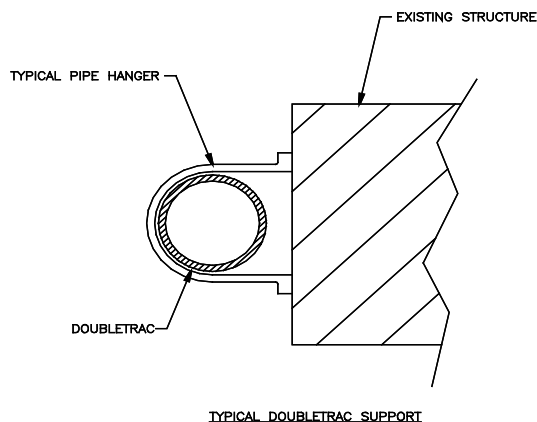

### Marina Installations

#### Fixed Dock

When installing DoubleTrac® on a fixed dock, the piping may be run along the side or underneath it. In either case, the routing must be such that it cannot be damaged, crush, kinked during normal use of the dock. The piping must be supported evenly along the entire run; supports are required every six feet. Typical supports are Unistrut conduit hangers, “U” bolts, PVC pipe couplers, or Hosebuns.

#### Floating Dock

DoubleTrac® should not be installed on the walkway from the shore to the dock. The constant flexing due to tide changes will cause fatigue and possible failure of the primary piping. The dock to shore connection should be an approved flexible connector. DoubleTrac® piping can be installed along the length of the floating dock portion. The routing must be such that it cannot be damaged, crush, kinked during normal use of the dock. The piping must be supported evenly along the entire run; supports are required every six feet. Typical supports are Unistrut conduit hangers, “U” bolts, PVC pipe couplers, or Hosebuns.

### ▲ CAUTION

**DoubleTrac® piping is not an approved flex connector. Please contact OmegaFlex Engineering Department for flexible double contained dock connectors at 1-800-355-1039.**

### Routine Maintenance and Visual Inspections

It is recommended that a visual inspection of all components as well as the inside of all containment sumps be completed at least once per month. Typical monthly inspections include, but are not limited to:

- visual inspection of piping: no visible damage to the outer jacket such as cracks, crushing, kinking, or puncture
- visual inspection of all mounting hardware: all hardware must be intact and securely mounted in the original location
- visual inspection of DoubleTrac fittings: no visible damage to fittings, no sign of leakage, any vent/test port fittings or bypass hoses should show no sign of crushing, kinking, or puncture.

Fuel leaks collected in containment sumps must be reported immediately and investigated by the site owner. If leakage or damage to the piping system is observed or suspected, OmegaFlex must be notified immediately. All sumps must be kept free of fuel, water and debris. When changing fuel filters at the dispenser, make sure any spilled product is cleaned out of the bottom of the dispenser sump to prevent possible fire hazard.

### Contact Information

OmegaFlex Inc. can be contacted if there are any questions concerning the installation, maintenance or repair of DoubleTrac® flexible piping system. Please contact OmegaFlex customer service and 1-800-355-1035 or on the web at [www.omegaflex.com](http://www.omegaflex.com) or [www.doubletrac.net](http://www.doubletrac.net).

## LIMITED WARRANTY- Above Ground and Marina

PRODUCT	LENGTH OF WARRANTY
DoubleTrac flexible petroleum pipe	15 years
DoubleTrac Fittings	1 year

Omega Flex, Inc. warrants to the purchaser of the DoubleTrac® flexible piping system that the products listed above (the “Product”) when installed in above ground applications or on fixed or floating docks will be free from defects in material or workmanship for period stated above, as measured from the date of shipment from DoubleTrac. This excludes DoubleTrac dock connectors which are covered under a separate warranty.

If upon examination, the Product is shown to have a defect in material or workmanship during the warranty period, DoubleTrac will, at its option, either repair or replace that part of the Product which is shown to be defective, or issue a credit for the amount of the defective product that may be applied to future orders of the Product.

### This limited warranty does not apply:

- If the Product has been subjected to misuse or neglect, has been accidentally or intentionally damaged, or has been altered or modified in any way.
- If the Product has been repaired by anyone who is not a DoubleTrac authorized service representative.
- If the Product has not been installed in accordance with the DoubleTrac installation guidelines.
- If the Product has been installed with unauthorized third party components, except those components that are recommended for use with DoubleTrac in the DoubleTrac installation guide.
- To any costs or expenses incurred during investigation, removal or reinstallation of the defective Product, including without limitation any costs or expenses for clean-up, downtime, or lost profits.
- To any damage or impairment of the Product caused by any casualty, including without limitation fires, storms, floods, earthquakes, or acts of God.
- To any workmanship of the installer of the Product.

### This limited warranty is conditional upon:

- Receipt of a written warranty claim during the applicable warranty period.
- Installation of the Product by an individual who has received factory authorized training on the installation and proper use of DoubleTrac.
- All site and warranty registration forms are completed and received by DoubleTrac within 30 days of installation.
- All piping and connections are installed with an approved leak detection device in each tank and dispenser sump.
- A sump inspection log or EPA checklist is maintained and provided to DoubleTrac on request.
- DoubleTrac receives notice of warranty claim within 24 hours of any known or suspected failure of the Product.

Product can only be returned with prior written approval from DoubleTrac. All returns must be freight prepaid. Manufacturer will inspect the alleged defective part, and provide the customer with the results of that inspection whether or not in the reasonable opinion of DoubleTrac, that there exists a defect in material or workmanship. Repair or replacement of any part under this Limited Warranty shall not extend the duration of the warranty with respect to such repaired or replaced part beyond the stated warranty period.

### IMPORTANT

This limited warranty is in lieu of all other warranties, either express or implied, and all such other warranties, including without limitation implied warranties of merchantability or fitness for a particular purpose, are hereby disclaimed and excluded from this limited warranty.

### LIMITATION OF LIABILITY

In no event will DoubleTrac be liable in any way for (a) any consequential, special, or incidental damages of any nature whatsoever, or (b) any amounts in excess of the selling price of the Product or any parts thereof found to be defective.

## LIMITED WARRANTY- Below Ground

PRODUCT	LENGTH OF WARRANTY
DoubleTrac flexible petroleum pipe	30 years
DoubleTrac Fittings	1 year

Omega Flex, Inc. warrants to the purchaser of the DoubleTrac® flexible piping system that the products listed above (the “Product”) when installed in above ground applications will be free from defects in material or workmanship for period stated above, as measured from the date of shipment from DoubleTrac.

If upon examination, the Product is shown to have a defect in material or workmanship during the warranty period, DoubleTrac will, at its option, either repair or replace that part of the Product which is shown to be defective, or issue a credit for the amount of the defective product that may be applied to future orders of the Product.

### This limited warranty does not apply:

- If the Product has been subjected to misuse or neglect, has been accidentally or intentionally damaged, or has been altered or modified in any way.
- If the Product has been repaired by anyone who is not a DoubleTrac authorized service representative.
- If the Product has not been installed in accordance with the DoubleTrac installation guidelines.
- If the Product has been installed with unauthorized third party components, except those components that are recommended for use with DoubleTrac in the DoubleTrac installation guide.
- To any costs or expenses incurred during investigation, removal or reinstallation of the defective Product, including without limitation any costs or expenses for clean-up, downtime, or lost profits.
- To any damage or impairment of the Product caused by any casualty, including without limitation fires, storms, floods, earthquakes, or acts of God.
- To any workmanship of the installer of the Product.

### This limited warranty is conditional upon:

- Receipt of a written warranty claim during the applicable warranty period.
- Installment of the Product by an individual who has received factory authorized training on the installation and proper use of DoubleTrac.
- All site and warranty registration forms are completed and received by DoubleTrac within 30 days of installation.
- All piping and connections are installed with an approved leak detection device in each tank and dispenser sump.
- A sump inspection log or EPA checklist is maintained and provided to DoubleTrac on request.
- DoubleTrac receives notice of warranty claim within 24 hours of any known or suspected failure of the Product.

Product can only be returned with prior written approval from DoubleTrac. All returns must be freight prepaid. Manufacturer will inspect the alleged defective part, and provide the customer with the results of that inspection whether or not in the reasonable opinion of DoubleTrac, that there exists a defect in material or workmanship. Repair or replacement of any part under this Limited Warranty shall not extend the duration of the warranty with respect to such repaired or replaced part beyond the stated warranty period.

### IMPORTANT

This limited warranty is in lieu of all other warranties, either express or implied, and all such other warranties, including without limitation implied warranties of merchantability or fitness for a particular purpose, are hereby disclaimed and excluded from this limited warranty.

### LIMITATION OF LIABILITY

In no event will DoubleTrac be liable in any way for (a) any consequential, special, or incidental damages of any nature whatsoever, or (b) any amounts in excess of the selling price of the Product or any parts thereof found to be defective.



**Omega Flex, Inc.**

451 Creamery Way, Exton, PA 19341-2509  
800-355-1039 • Fax 610-524-6484

**Corporate Offices**

213 Court Street, Suite 701, Middletown, CT 06457  
860-704-6820 • Fax 860-704-6830

*[www.omegaflex.com](http://www.omegaflex.com)*

ISO 9001 Registered Company